



# Table of Contents

Product Description	1
CS485 Configuration & Setup	2
4-wire Operation	2
2-wire Operation	2
Dual Port Operation	2
Carrier Detect	2
Transmitter Control	3
Baud Rate Selection	3
Keydown Delay	3
CTS Delay	3
J10 Jumper Settings	4
Baud Rate Selection	4
Keydown Selection	4
Data/DCD Jumper	4
Data RTS Jumper	4
J13 Jumper Settings	4
CTS Delay	4
RS-485 RX and TX Jumpers	5
Line Termination	5
Transient Protection and Grounding	6
Transient Protection	6
Shield Connection	6
Static Control	6
Connectors	8
Power	8
RS-232	8
RS-485	8
RJ11	8
Product Specification	9
Trouble Shooting	10
Appendix A	11
Half-Duplex Jumper Configuration	11
Full-Duplex Jumper Configuration	12
JCI – N2 Bus Jumper Configuration	13

## Product Description

The CS485 line driver is an RS-232 to RS-485 interface converter. It allows an RS-232 device to reliably transmit data over long distances (up to 4000 feet). The CS485 has many features not normally found in typical line drivers, and is intended for operation in harsh industrial environments.

The CS485 may be used in point-to-point applications as well as multi-drop applications using either 4-wire or 2-wire configurations. Up to 32 devices may be connected together on one communication line.

The CS485 can also be used as a dual-port half-duplex splitter. As a master, the CS485 can talk to two trunks of up to 31 half-duplex devices. This allows the CS485 to talk to up to 62 devices.

A variety of timing and control options are available on the CS485. An RTS to CTS delay provides the ability to turn on the RS-485 transmitter before sending data to allow the communication line to stabilize. RS-485 transmitter control may be implemented using the RS-232 RTS signal or the presence of RS-232 TX data.

A unique capability of the CS485 is the ability to sense the presence of a received RS-485 carrier (remote RS-485 driver enabled). This is very useful for controlling devices that require a turn-on delay before data can be transmitted like radio modems. The carrier detect signal can also be based on the presence of received RS-485 data.

All timing functions are crystal controlled and provide very accurate and stable delays. Temperature and voltage fluctuations will not affect the CS485's operation.

The CS485 has 1500 volt optical isolation between the RS-232 side and the RS-485 side. The RS-485 lines are protected with 2 stages of surge protection, and jumpers allow complete configuration of terminating and pull up/down functions.

## **CS485 Configuration and Setup**

### **4-wire Operation (J8 OUT)**

4-wire operation provides full-duplex capability for point-to-point configurations. A 4-wire 'half-duplex' configuration is also useful where the master unit is always transmitting to the slave units, and the slave units respond to the master in half-duplex style. This simplifies the control software for the master, and can provide a speed advantage over 2-wire half-duplex configurations. The slave units can enable their transmitters using either RTS control or data control.

### **2-wire Dual Port Operation (J8 IN)**

Multi-drop applications typically use a 2-wire configuration. Installation requires a single twisted pair, and all nodes can talk to each other. Many applications use a single master with multiple slaves.

The CS485 is capable of dual port 2-wire operation. If J8 is installed, the RX and TX pairs both operate as half-duplex ports. A CS485 configured for dual-port operation can communicate with 2 trunks of half duplex slaves. This allows the CS485 to talk to 2 trunks of 31 slaves or 62 slaves total.

### **Carrier Detect**

A feature available on the CS485 that is not available on most line drivers is the ability to detect when a remote line driver has turned on its transmitter. This is useful for controlling other equipment that may require carrier control like radio modems. This signal is passed to the RS-232 port as the Data Carrier Detect (DCD) signal.

Carrier detect works by sensing a voltage level greater than 850mV between the RX+ and RX- wires. Built-in hysteresis prevents the DCD signal from oscillating in noisy environments. The pull-up, pull-down and termination jumpers (J4, J3 and J2) must be installed on each end of the communication line for proper operation. The DCD output will maintain its last state when the RTS signal is asserted and the CS485 is used to transmit data.

Carrier detect can also be asserted based on the presence of received data. If the DCD jumper on J10 is installed, the RS-232 DCD signal is asserted when incoming RS-485 data is received. The DCD signal is asserted as soon as RS-485 data is detected. Following the last character, the DCD signal is held active for the delay time set by the Keydown Delay jumpers before being de-asserted. The baud rate jumpers on J10 must be set to the desired baud rate.

### **Transmitter Control**

The CS485's RS-485 transmitter may be controlled by either the RS-232 RTS control signal or the presence of data on the RS-232 TX data pin. If the RTS signal is used to control the transmit function, any data format or baud rate may be used.

If TX data is used to control the transmit function, the desired baud rate must be set using the jumpers on J10 and a data format of 1 start bit, 8 data bits and 1 stop bit is assumed. The length of time that the RS-485 transmitter remains enabled following the end of the last character is determined by the Keydown Delay jumpers.

### **Baud Rate Selection**

Jumper J10 is used to select the desired baud rate. Baud rates range from 1200 to 115.2K. The CS485 expects a data structure of 1 start bit, 8 data bits and 1 stop bit.

### **Keydown Delay**

Keydown delay refers to how long a control signal remains active following the last bit of the last character being sent.

If the RS-485 transmitter is being controlled by RS-232 TX data (J10 RTS jumper installed), then the transmitter will remain enabled for the time duration specified by the Keydown jumpers following the end of the last character.

If the RS-232 DCD signal is based on received RS-485 data (J10 DCD jumper installed), then the DCD signal will remain asserted for the time duration specified by the Keydown jumpers following the end of the last received character.

Delays can range from 100us to 12.8ms.

### **CTS Delay**

The CTS delay jumpers provide a delay from the time the RS-232 RTS signal is asserted until the time the RTS-232 CTS signal is asserted back to the controlling device. This is useful for providing a delay before transmit (keyup delay), and relieves the controlling device from generating precise timing functions. Delays range from 0ms to 12.8ms.

## J10 Jumper Settings

### BAUD Rate Selection

BAUD2	BAUD1	BAUD0	BAUD RATE
o	o	o	1200
o	o	•	2400
o	•	o	4800
o	•	•	9600
•	o	o	19.2K
•	o	•	38.4K
•	•	o	56.7K
•	•	•	115.2K

### KEYDOWN Selection

KEYDN2	KEYDN1	KEYDN0	KEYDOWN TIME
o	o	o	100us
o	o	•	200us
o	•	o	400us
o	•	•	800us
•	o	o	1.6ms
•	o	•	3.2ms
•	•	o	6.4ms
•	•	•	12.8ms

o Denotes no jumper installed

• Denotes jumper installed

### DATA/DCD Jumper

IN DCD RS-232 output based on RS-485 received data

OUT DCD RS-232 output based on detected RS-485 carrier

### DATA/RTS Jumper

IN RS-485 transmit enable based on RS-232 transmit data

OUT RS-485 transmit enable based on RS-232 RTS signal

## J13 Jumper Settings

### RTS to CTS Delay

CTS DELAY2	CTS DELAY1	CTS DELAY0	RTS to CTS Delay Time
o	o	o	0
o	o	•	200us
o	•	o	400us
o	•	•	800us
•	o	o	1.6ms
•	o	•	3.2ms
•	•	o	6.4ms
•	•	•	12.8ms

## RS-485 RX and TX Jumpers

J4 – Enable pull-up resistor for RX+ line  
J3 – Enable pull-down resistor for RX- line  
J2 – Terminate RX pair with 120 ohm resistor

J7 – Enable pull-up resistor for the TX+ line  
J6 – Enable pull-down resistor for the TX- line  
J5 – Terminate TX pair with 120 ohm resistor

J8    IN    Enables 2-wire operation for both RX and TX pairs  
              (Dual port operation)

      OUT    Enables 4-wire operation  
              RX is receive pair  
              TX is transmit pair

J15    Connects isolated RS-485 common to bleed resistor and filter cap

### Line Termination

The CS485's termination jumpers should only be installed if the CS485 is physically at one end of the trunk.

To terminate the RX pair, install jumpers J2, J3 and J4.

To terminate the TX pair, install jumpers J5, J6 and J7.

## **Transient Protection and Grounding**

### **Transient Protection**

The CS485 has 2-stages of transient protection. The first stage connects each RS-485 data line to a SiDACtor. The common side of the SiDACtor's are connected to the "EARTH" terminal of J9 (Figure 1). SiDACtor's provide ultra-fast transient response and provide a path to earth ground for high-voltage transients. The second stage of transient protection uses Transorbs which are connected to the isolated common of the RS-485 section. The Transorbs make sure all transient signals are clamped to within the normal operating voltage of the RS-485 electronics.

Under certain conditions, some devices introduce a large ac or dc voltage on the RS-485 communication lines (referred to as common-mode voltage). This does not present a problem unless the common-mode voltage exceeds the SiDACtor's clamping voltage. If common-mode voltages in excess of 25V are expected, leave the connection from J9-3 (Earth) to ground open so that the SiDACtor's will not try to clamp the common-mode voltage to earth ground. The SiDACtor's and Transorbs will still provide transient protection, but not as effectively for very large transients (lightning for example). Leaving the Earth connection open allows the CS485 to operate reliably with common-mode voltages in excess of 100V.

### **Shield Connection**

The isolated ground or common of the CS485 is connected to J1-3 (SHLD). The shield wires of the communication cables are normally connected to this point. Care must be taken to avoid ground loops. Only one end of the shield should be connected to earth ground. Under some conditions other devices may induce a large common-mode voltage on the shield wire. Under these circumstances, leave the CS485's connection to earth ground (J9-3) open (see "CS485 Transient Protection and Grounding", and Figure 1).

### **Static Control**

When jumper J15 is installed and J9-3 is connected to earth ground, the CS485 provides a "bleed resistor" which prevents static voltage buildup on the isolated section. The bleed resistor ensures that the isolated section is always at a safe voltage potential. The same connection provides a filter cap which shunts any high-frequency noise that may be induced on the RS-485 communication lines to earth ground.

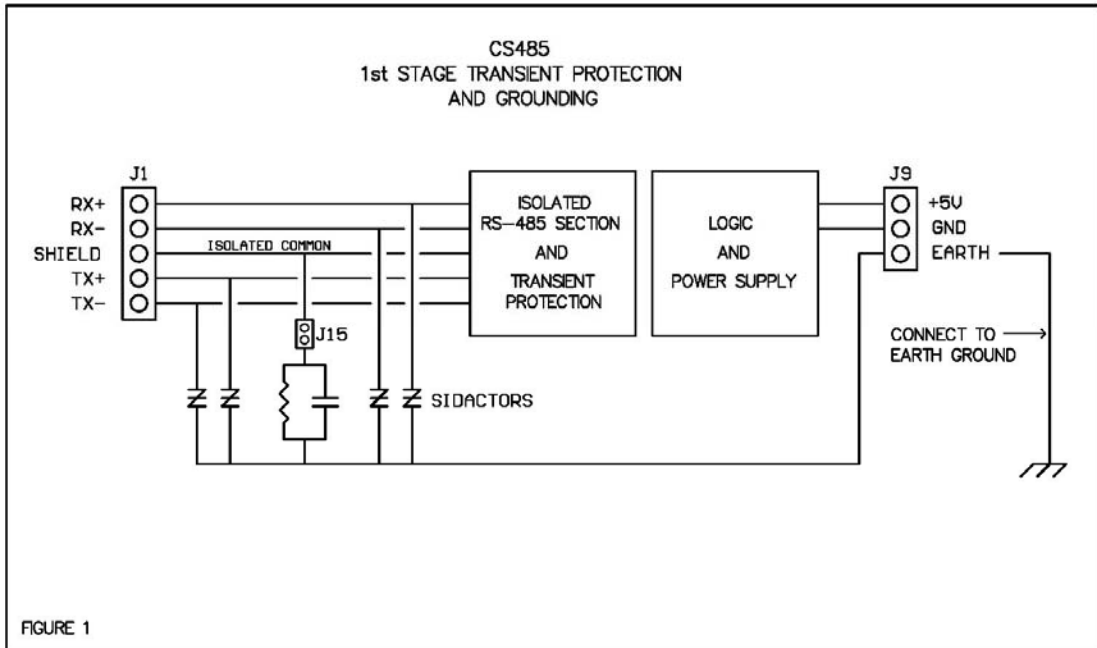

## Connectors

### Power (J9)

Pin	Description
J9-1	+5 Vdc (CS485-5) +8Vdc to +35Vdc (CS485-24)
J9-2	Common for J9-1
J9-3	Earth Ground

### RS-232 (J14)

Pin	Description	Signal
J14-1	TX Data	Input
J14-2	RX Data	Output
J14-3	RTS	Input
J14-4	CTS	Output
J14-5	DCD	Output
J14-6	DSR	Output
J15-7	Common	Ground

### RS-485 (J1)

Pin	Description
J1-1	RX+
J1-2	RX-
J1-3	Isolated Common (Shield)
J1-4	TX+
J1-5	TX-

### RJ11

Pin	Description	Signal
Pin 1	CTS	Output
Pin 2	TX Data	Input
Pin 3	no connection	
Pin 4	Common	
Pin 5	RX Data	Output
Pin 6	RTS	Input

## CS485 Specifications

MODEL	CS485-5V	CS485-24V
Power	5Vdc 250mA to 350mA	8 to 35 Vdc 300mA to 90mA 110mA @ 24 Vdc typ
Operating Temperature	0 – 70DegC	0 – 70DegC
Operating Modes	4-wire full-duplex 4-wire half-duplex 2-wire half-duplex 2-wire half-duplex	Single Port Dual Port
Transmit Control	RS-232 RTS RS232 Tx Data	RTS Mode Data Mode
Carrier Detect	RS-485 received carrier RS-485 received data	DCD Mode Data Mode
Delay Functions	RS-232 RTS to CTS RS-485 Tx Keydown DCD Data Delay	Tx enable delay Tx turnoff delay DCD turnoff in data mode
Operation Display	Tx, Rx, RTS, DCD & Power LED's	Tx, Rx, RTS, DCD & Power LED's
Isolation	1500 Volt Isolation	Optically Isolated
Surge Protection	2 stages of protection Sidactor + Transorb and 15kV ESD protection on RS-232 port	2 stages of protection Sidactor + Transorb and 15kV ESD protection on RS-232 port
Power Protection	Input reversal protection Transorb surge protection Solid state fuse	Input reversal protection Transorb surge protection Solid state fuse
Mounting	3.25" Snap Track	Curtis Industries, TR3

## **Trouble Shooting**

### **Erratic DCD and RX LEDs**

If the DCD and/or RX LEDs appear to flicker erratically when the CS485 is connected to an active RS-485 trunk, a large common-mode voltage may be present. Measure the voltage on the RX+ and RX- lines with respect to earth ground. If the voltage exceeds 25 V (ac or dc), disconnect the ground connection from J9 pin 3.



# FULL DUPLEX JUMPER CONFIGURATION

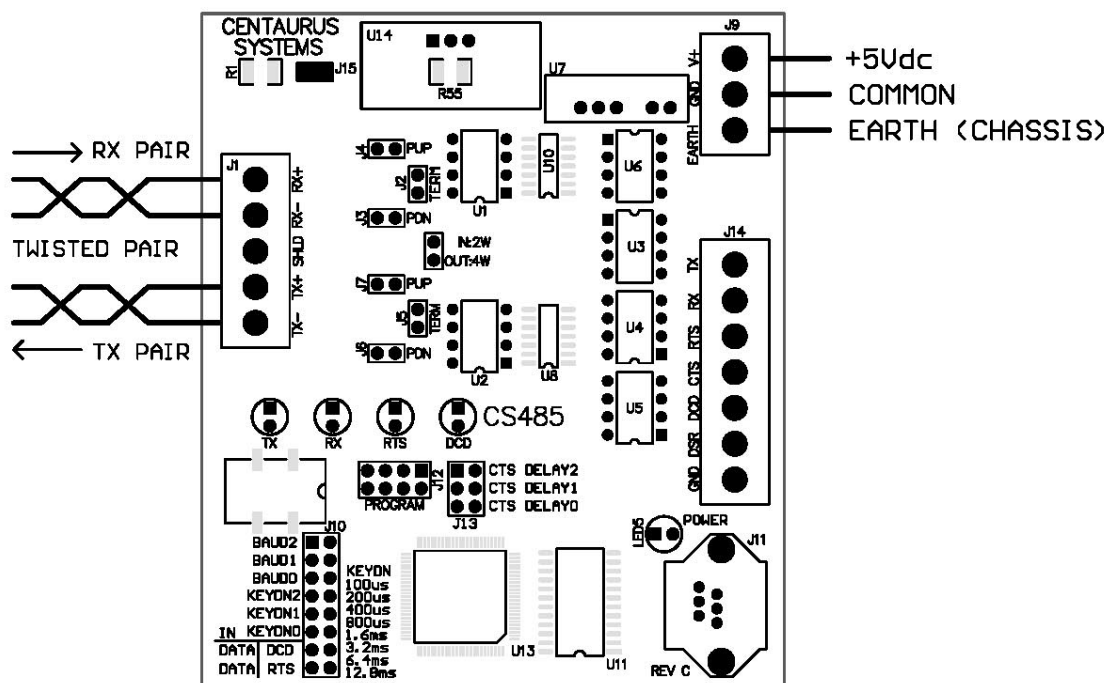

## INSTALLED JUMPERS

J2 - RX TERM	(END OF LINE ONLY)
J3 - RX PULL DOWN	(END OF LINE ONLY)
J4 - RX PULL UP	(END OF LINE ONLY)
J5 - TX TERM	(END OF LINE ONLY)
J6 - TX PULL DOWN	(END OF LINE ONLY)
J7 - TX PULL UP	(END OF LINE ONLY)
J15 - STATIC BLEED	

